

LED E26/E27/E39/E40 High Bay Light SE Series

Product Type	Specifications				Drawing
	Item	MD-SE-30W	Luminous Flux	3000-3450LM	
	Power	30W	CRI	≥80	
	Power Efficiency	>87 %	led chip brand	CREE XTE	
	Input Voltage	AC100-305V	Light Color	2700-7000K	
	Frequency range	50Hz-60Hz	Beam Angle	60° 90° 120°	
	Power Factor	>0.95	Lamp Base	E26/E27/E39/E40	
	Life span	≥50,000 Hrs	Size	125*220mm	
	Material	Fin radiator	Gross Weight	0.7kg	
	Item	MD-SE-50W	Luminous Flux	5000-5750LM	
	Power	50W	CRI	≥80	
	Power Efficiency	>87 %	led chip brand	CREE XTE	
	Input Voltage	AC100-305V	Light Color	2700-7000K	
	Frequency range	50Hz-60Hz	Beam Angle	60° 90° 120°	
	Power Factor	>0.95	Lamp Base	E26/E27/E39/E40	
	Life span	≥50,000 Hrs	Size	125*220mm	
	Material	Fin radiator	Gross Weight	0.7kg	
	Item	MD-SE-60W	Luminous Flux	6000-6900LM	
	Power	60W	CRI	≥80	
	Power Efficiency	>87 %	led chip brand	CREE XTE	
	Input Voltage	AC100-305V	Light Color	2700-7000K	
	Frequency range	50Hz-60Hz	Beam Angle	60° 90° 120°	
	Power Factor	>0.95	Lamp Base	E26/E27/E39/E40	
	Life span	≥50,000 Hrs	Size	125*220mm	
	Material	Fin radiator	Gross Weight	0.7kg	
	Item	MD-SE-80W	Luminous Flux	8000-9200LM	
	Power	80W	CRI	≥80	
	Power Efficiency	>87 %	led chip brand	CREE XTE	
	Input Voltage	AC100-305V	Light Color	2700-7000K	
	Frequency range	50Hz-60Hz	Beam Angle	60° 90° 120°	
	Power Factor	>0.95	Lamp Base	E26/E27/E39/E40	
	Life span	≥50,000 Hrs	Size	125*220mm	
	Material	Fin radiator	Gross Weight	0.7kg	
	Item	MD-SE-100W	Luminous Flux	10000-11500LM	
	Power	100W	CRI	≥80	
	Power Efficiency	>87 %	led chip brand	CREE XTE	
	Input Voltage	AC100-305V	Light Color	2700-7000K	
	Frequency range	50Hz-60Hz	Beam Angle	60° 90° 120°	
	Power Factor	>0.95	Lamp Base	E26/E27/E39/E40	
	Life span	≥50,000 Hrs	Size	165*230mm	
	Material	Fin radiator	Gross Weight	1.3kg	

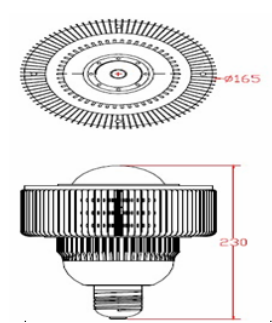

Item	MD-SE-120w	Luminous Flux	12000-13800LM
Power	120W	CRI	≥80
Power Efficiency	>87 %	led chip brand	CREE XTE
Input Voltage	AC100-305V	Light Color	2700-7000K
Frequency range	50Hz-60Hz	Beam Angle	60° 90° 120°
Power Factor	>0.95	Lamp Base	E26/E27/E39/E40
Life span	≥50,000 Hrs	Size	165*230mm
Material	Fin radiator	Gross Weight	1.3kg



Item	MD-SE-150w	Luminous Flux	15000-17250LM
Power	150W	CRI	≥80
Power Efficiency	>87 %	led chip brand	CREE XTE
Input Voltage	AC100-305V	Light Color	2700-7000K
Frequency range	50Hz-60Hz	Beam Angle	60°90° 120°
Power Factor	>0.95	Lamp Base	E26/E27/E39/E40
Life span	≥50,000 Hrs	Size	165*240mm
Material	Fin radiator	Gross Weight	1.3kg

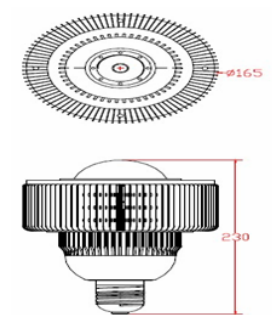

Item	MD-SE-180w	Luminous Flux	18000-20700LM
Power	180W	CRI	≥80
Power Efficiency	>87 %	led chip brand	CREE XTE
Input Voltage	AC100-305V	Light Color	2700-7000K
Frequency range	50Hz-60Hz	Beam Angle	60°90° 120°
Power Factor	>0.95	Lamp Base	E26/E27/E39/E40
Life span	≥50,000 Hrs	Size	165*240mm
Material	Fin radiator	Gross Weight	1.3kg

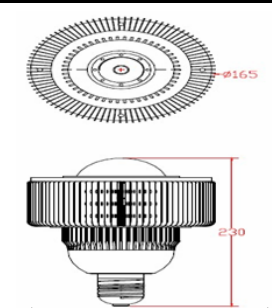

Item	MD-SE-200w	Luminous Flux	20000-23000LM
Power	200W	CRI	≥80
Power Efficiency	>87 %	led chip brand	CREE XTE
Input Voltage	AC100-305V	Light Color	2700-7000K
Frequency range	50Hz-60Hz	Beam Angle	60°90° 120°
Power Factor	>0.95	Lamp Base	E26/E27/E39/E40
Life span	≥50,000 Hrs	Size	298*187mm
Material	Fin radiator	Gross Weight	1.42kg

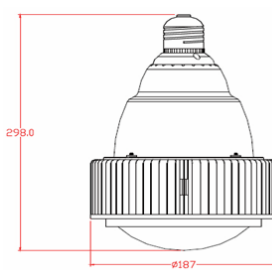

Item	MD-SE-250w	Luminous Flux	25000-28750LM
Power	250W	CRI	≥80
Power Efficiency	>87 %	led chip brand	CREE XTE
Input Voltage	AC100-305V	Light Color	2700-7000K
Frequency range	50Hz-60Hz	Beam Angle	60°90° 120°
Power Factor	>0.95	Lamp Base	E26/E27/E39/E40
Life span	≥50,000 Hrs	Size	298*187mm
Material	Fin radiator	Gross Weight	1.42kg

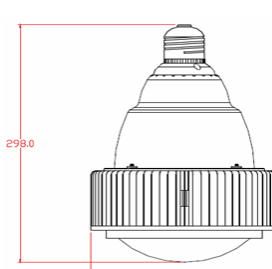

Item	MD-SE-300W	Luminous Flux	30000-34500LM
Power	300W	CRI	≥80
Power Efficiency	>87 %	led chip brand	CREE XTE
Input Voltage	AC100-305V	Light Color	2700-7000K
Frequency range	50Hz-60Hz	Beam Angle	60°90° 120°
Power Factor	>0.95	Lamp Base	E26/E27/E39/E40
Life span	≥50,000 Hrs	Size	330*187mm
Material	Fin radiator	Gross Weight	1.85kg

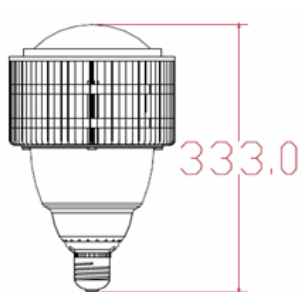



Item		Luminous Flux	5500-6000LM
Power	50W	CRI	≥80
Power Efficiency	>87 %	led chip brand	EPISTAR 5730
Input Voltage	AC100-305V	Light Color	2700-7000K
Frequency range	50Hz-60Hz	Beam Angle	120°
Power Factor	>0.95	Lamp Base	E26/E27/E39/E40
Life span	≥50,000 Hrs	Size	125*220mm
Material	Fin radiator	Gross Weight	0.7kg

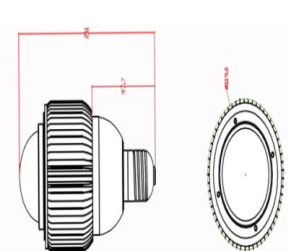

Item	MD-SE-60W-B(SMD)	Luminous Flux	6600-7200LM
Power	60W	CRI	≥80
Power Efficiency	>87 %	led chip brand	EPISTAR 5730
Input Voltage	AC100-305V	Light Color	2700-7000K
Frequency range	50Hz-60Hz	Beam Angle	120°
Power Factor	>0.95	Lamp Base	E26/E27/E39/E40
Life span	≥50,000 Hrs	Size	125*220mm
Material	Fin radiator	Gross Weight	0.7kg

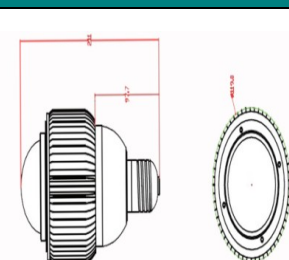

Item	MD-SE-80W-B(SMD)	Luminous Flux	8800-9600LM
Power	80W	CRI	≥80
Power Efficiency	>87 %	led chip brand	EPISTAR 5730
Input Voltage	AC100-305V	Light Color	2700-7000K
Frequency range	50Hz-60Hz	Beam Angle	120°
Power Factor	>0.95	Lamp Base	E26/E27/E39/E40
Life span	≥50,000 Hrs	Size	125*220mm
Material	Fin radiator	Gross Weight	0.7kg

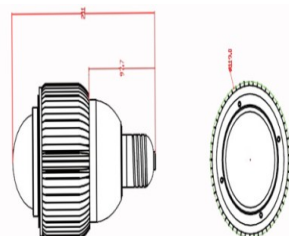

Item	MD-SE-100W-B(SMD)	Luminous Flux	11000-12000LM
Power	100W	CRI	≥80
Power Efficiency	>87 %	led chip brand	EPISTAR 5730
Input Voltage	AC100-305V	Light Color	2700-7000K
Frequency range	50Hz-60Hz	Beam Angle	120°
Power Factor	>0.95	Lamp Base	E26/E27/E39/E40
Life span	≥50,000 Hrs	Size	165*230mm
Material	Fin radiator	Gross Weight	1.3kg

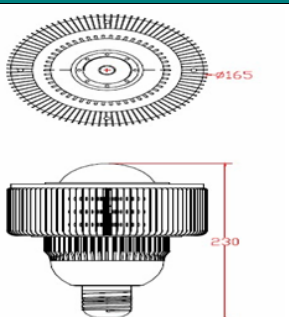

Item	MD-SE-120W-B (SMD)	Luminous Flux	13200-14400LM
Power	120W	CRI	≥80
Power Efficiency	>87 %	led chip brand	EPISTAR 5730
Input Voltage	AC100-305V	Light Color	2700-7000K
Frequency range	50Hz-60Hz	Beam Angle	120°
Power Factor	>0.95	Lamp Base	E26/E27/E39/E40
Life span	≥50,000 Hrs	Size	165*240mm
Material	Fin radiator	Gross Weight	1.3kg

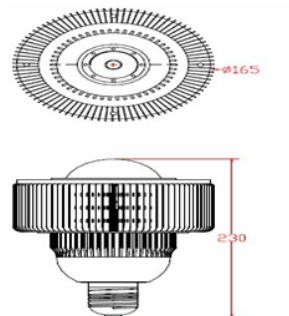

Item	MD-SE-150w-B (SMD)	Luminous Flux	16500-18000LM
Power	150W	CRI	≥80
Power Efficiency	>87 %	led chip brand	EPISTAR 5730
Input Voltage	AC100-305V	Light Color	2700-7000K
Frequency range	50Hz-60Hz	Beam Angle	120°
Power Factor	>0.95	Lamp Base	E26/E27/E39/E40
Life span	≥50,000 Hrs	Size	165*240mm
Material	Fin radiator	Gross Weight	1.3kg

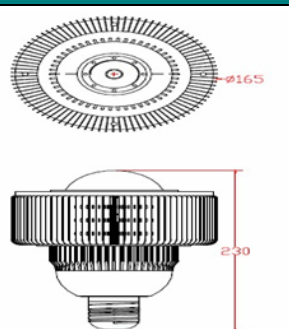



Item	MD-SE-180w-B(SMD)	Luminous Flux	19800-21600LM
Power	180W	CRI	≥80
Power Efficiency	>87 %	led chip brand	EPISTAR 5730
Input Voltage	AC100-305V	Light Color	2700-7000K
Frequency range	50Hz-60Hz	Beam Angle	120°
Power Factor	>0.95	Lamp Base	E26/E27/E39/E40
Life span	≥50,000 Hrs	Size	165*240mm
Material	Fin radiator	Gross Weight	1.3kg

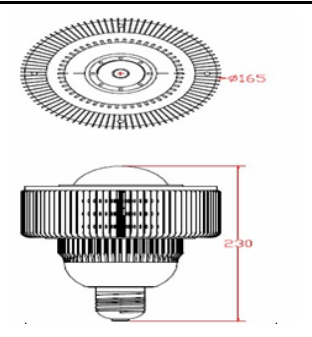

45°



90°



120°



Aluminum alloy reflector

Acrylic reflector

MEAS:43.7*43.7*45CM 45°:25PCS/CTN 90°/120°:50PCS/CTN

MEAS:43.7*43.7*45CM
25PCS/CTN